

SAFETY CABLE INSTALLATION INSTRUCTIONS

1.0: THREADING SAFETY CABLE

Components Required

Crosby clips, thimbles (for loads exceeding 200 lbs. [91 kg.]

¼" galvanized cable

Threading Procedure

- STEP 1. Slide thimbles together as shown in (Figure 1) below.
- STEP 2. Turn back a minimum of 4 .00" (100 mm) of the ¼" cable rope on the thimble or loop as shown in (Figure 2) below.
- STEP 3. Apply first Crosby clip 1.00" (25 mm) from "dead" end of rope. Apply U-bolt over "dead" end of wire rope - "live" end rests in Crosby Clip saddle. Tighten nuts evenly, alternating from one nut to the other until reaching a maximum torque achievable using a hand held wrench. (Torque must exceed a minimum of 7 ft./lbs.)
- STEP 4. Apply the second Crosby clip as near the thimble or loop as possible. Apply U-bolt over dead" end of wire rope - "live" end rests in Crosby Clip saddle. Tighten nuts evenly, alternating from one nut to the other until reaching a maximum torque achievable using a hand held wrench. (Torque must exceed a minimum of 7 ft./lbs.)

NOTE: Distance between the two Crosby Clips should not exceed one Crosby Clip width. If both the Crosby Clips are assembled next to each other, it does not affect the strength of the fastening system.

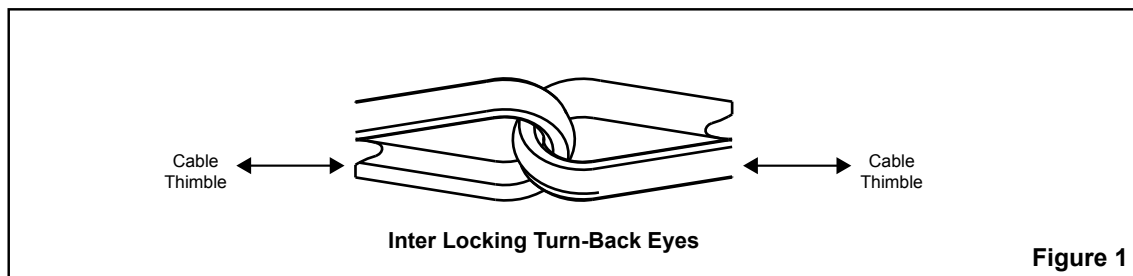

Figure 1

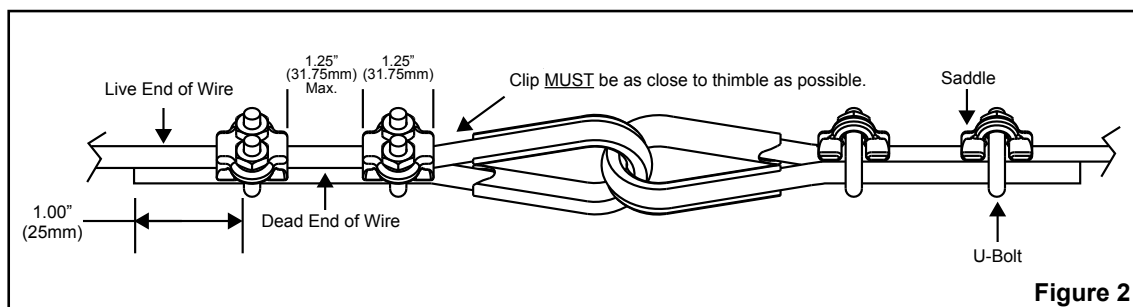

Figure 2

SAFETY CABLE INSTALLATION INSTRUCTIONS



⚠ NOTE

- Do not overlap cable ends. Use eye method with thimbles. See Figure 3-82.
- Finished safety cable assembly should be as snug as possible to minimize the load drop.

End Trucks (See Figure 3-85.)

- Step 1. Verify End truck is pre-cabled. End trucks should have cable pass under rail bracket.
- Step 2. Insert cable under hanger in bracket channel of rail and over structural beam.
- Step 3. Feed cable under hanger tap plate located underneath top channel lip.

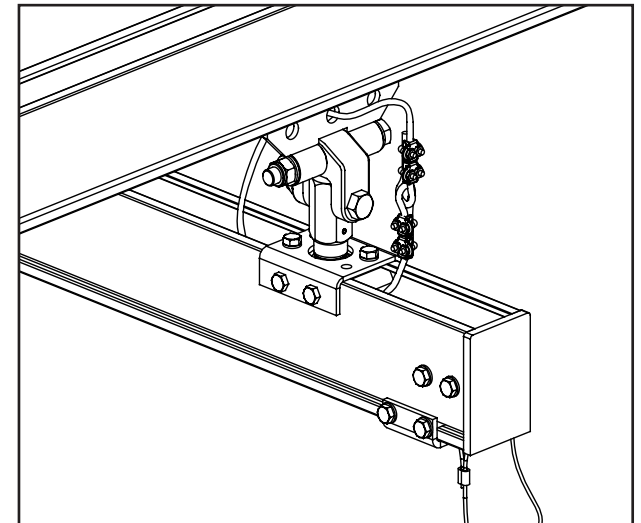

Figure 3-85 End Trucks